

teknion

the way back

solutions for healthy,
safe and productive work

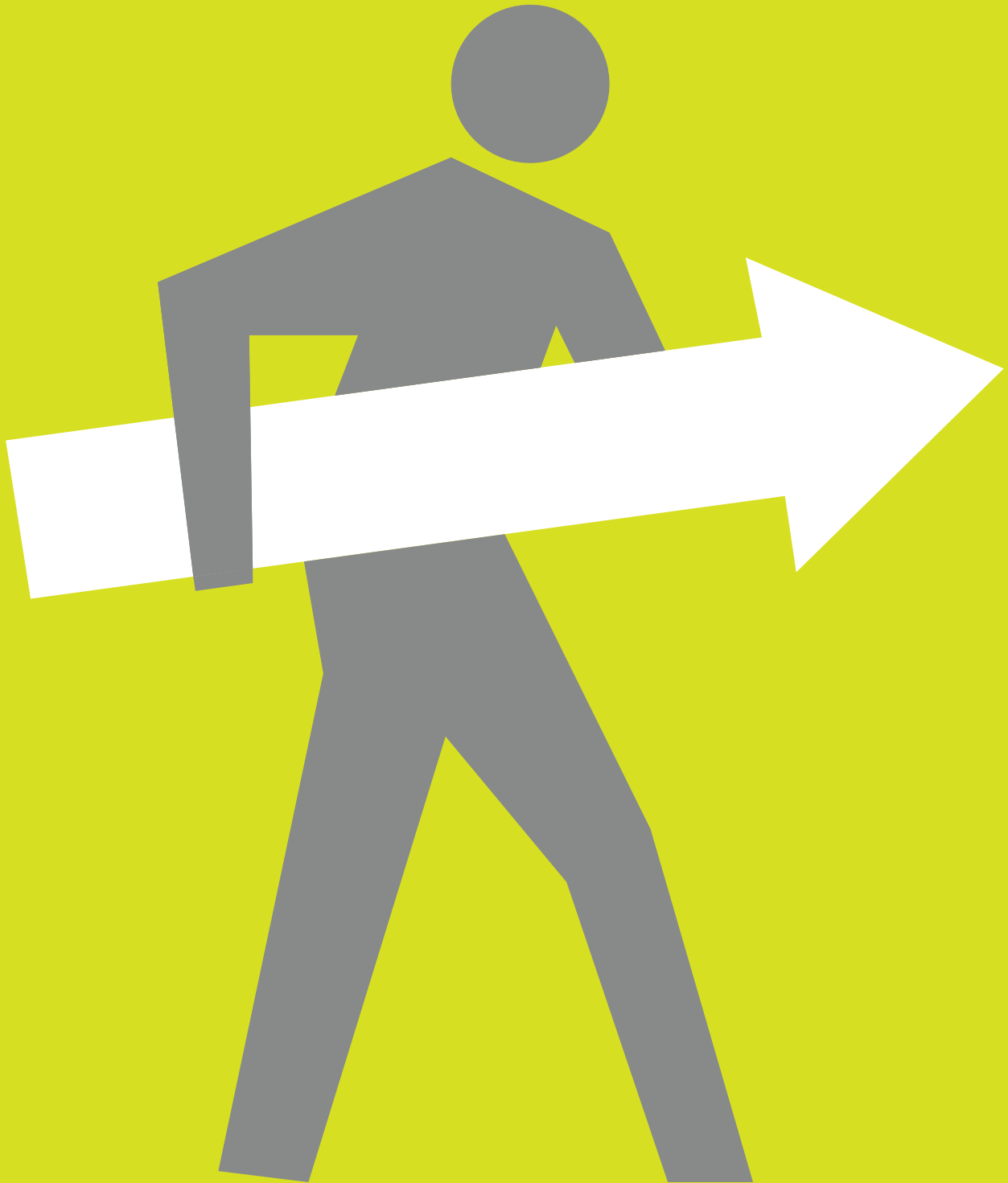

table of contents

introduction	03-11
the new rules of planning	12-18
workspace planning	19-32
social space planning	33-38
materials and cleaning solutions	39-44
color palettes	45-51
conclusion	52-53

teknion the way back\

this too
shall pass

persian saying

while a global pandemic has, for the moment, upended our personal and professional lives, the fundamentals of work are unlikely to change. on the other side of this disruptive event, we will still need to focus and collaborate, to mentor and to learn. we will look forward to sharing coffee and ideas with colleagues and clients.

in fact, we may more fully appreciate our life as social beings, the pleasure of gathering for an office happy hour or meeting up with co-workers at the local pub after hours. we might even enjoy a deadline-driven brainstorming session. as human beings, we gravitate towards others and certainly, we communicate best face to face, where we can read physical cues, gauge reactions, and adjust accordingly. this is why people still go to the office.

most of us have gained flexibility in when and where we work. we've learned to make the most of digital tools to perform the basics of work and can be productive almost anywhere. now, after weeks or months sequestered in our homes, we may see a shift in time spent at the office and working remotely in a coffee shop or in our own dining room.

in the face of uncertainty—economic crises, terrorist attacks, global pandemics—there is a tendency to indulge in catastrophic thinking. we pull back, anxious to know if this event will alter fundamental beliefs and normative behaviors. what is at risk when markets are volatile? how will storms and forest fires change our lives? after the hijackings of commercial flights, we now endure long lines at airport checkpoints as our baggage is screened and shoes removed. yet, we continue to travel freely as safety protocols are put in place. and one day, we will go back to the office.

persistence and
resilience only
come from having
been given the
chance to work
through difficult
problems.

gever tully

the global pandemic creates a new context for office design. we may need to rethink the ways we've simulated the comforts of home and opened up spaces in a way that alters the ratio of sociability and privacy. in recent years, private spaces yielded to open collaborative spaces. now, we will see structures like enclosed workstations re-emerge, re-invented, helping workers to control personal space. in fact, most of us need a degree of privacy or separation—not just for fear of a virus, but for focus and psychological comfort. social space will continue as a destination for conversation and relaxation, but the eroded boundaries between personal and shared space, individual and collective work, will again become distinct.

at the moment, daily life may be difficult, but i truly believe we will learn, adapt, and come out the other side with new knowledge and renewed clarity about how to create healthier environments and work towards a better world. epidemics are part of the cycle of life. and the sky will not fall. rather, this pause gives us a chance to reaffirm our respect and care for others—at work and in our communities.

big events may keep us apart in physical distance, but they can bring us together in spirit.

steve delfino,
vice president, marketing

the last of human freedoms is one's ability to choose one's attitude in a given set of circumstances.

flow

this graphic represents the flow of people from home into the urban setting and thence to the office and the workstation. within each of these spheres, there is potential for connection. however, trains and subways, sidewalks, doorways, and elevators are touch points that must be considered and rethought, with the goal of reducing density, allowing for

social distancing, and preventing viral transmission. how do we bring people safely back to work? strategies include flexible work-from-home policies, but equally, interventions by public entities to ensure a safer commute and by architects and building owners to improve our buildings.



HOME

WORK

a new model for the workplace

after weeks or months working at home, millions of people will begin to find their way back into the office—one that looks and works a bit differently. office space and culture will be altered in some degree in order for people to feel safe. companies will need to instill trust and confidence in employees through visible defenses against disease—like less densification and a u-turn from wide open floorplans. there will be a need to reinforce protocols like diligent cleaning and frequent handwashing with posted notices or other “nudges.” design thinking will be layered with social distancing thinking.

of course, companies and employees alike will continue to demand an office that supports performance and collaboration, that promotes engagement and inclusion. but in light of the present moment, and the near future of work, a new model must also deliver a degree of privacy and control, a perception of safety, and a sense that one’s physical and emotional wellness is prioritized, addressed and dealt with.

new attitudes and habits

- people will want more space and at least a semblance of privacy.
- social distancing may be the new normal, encouraged in terms of behavior (6' distancing), as well as planning (widely spaced desks and enclosure).
- employees may be willing to forego the comforts of a "domestic" workplace for greater safety and security.
- an awareness of potential transmission of viruses or bacteria via contact with surfaces may deter interaction with objects not "our own;" there may be more use of disposable, single use items (e.g, desk placemats).
- employees will be equipped with cleaning products to disinfect personal work areas, and will also follow new hygiene etiquette that includes frequent hand washing and wiping down common areas such as the company kitchen or café after use.
- employees may be asked to move in a clockwise, and only clockwise, direction around the office to minimize direct contact.

working apart: as individuals and teams

as people experience social distancing in the office, and perhaps loneliness when working at home, concerns arise around emotional health, while employees struggle to remain productive and engaged when isolated from peers.

team members will need to adjust to alternate means of engagement in the form of virtual meetings, whether participating remotely or in the office. companies may use this moment to invest in advanced conferencing tools such as augmented reality and virtual reality technologies. and given the tension between real estate costs and new spatial requirements (the 12' personal bubble), the criteria for face-to-face collaboration are likely to be amended.

should larger numbers of employees work primarily from home, companies will be faced with the challenge of maintaining corporate culture, training and mentoring employees, and reorganizing schedules and routines. remote employees may feel distracted without a dedicated workspace, and impaired by the lack of such workplace luxuries as dual or multiple monitors, proper ergonomic furniture and accessories, thus requiring corporate investment to support remote work.

teknion the way back\

the new rules of planning

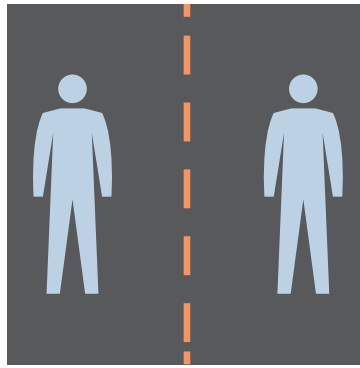

space



enclosures



materials



well being



comfort

space: distance

science offers evidence that social distancing is key to preventing viral spread. equally, distancing offers a sense of control and personal protection from an invisible hazard. in terms of planning, workstations can be reoriented. when developing a new floorplan, ideal corridor widths and the direction of traffic must be considered.

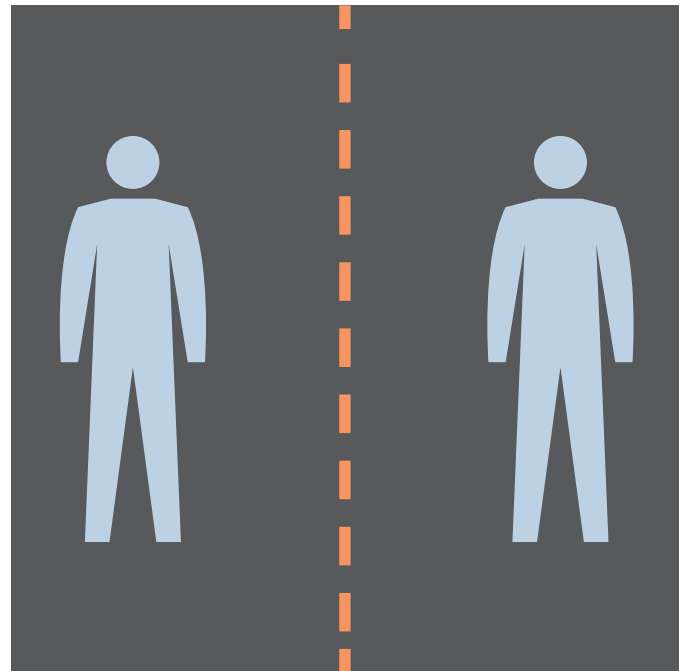

enclosures: protection and privacy

enclosures afford a degree of privacy, and perhaps more importantly protection and safety in the face of a pandemic. adding panels and screens in both opaque and transparent materials allows for varying degrees of openness and protection. higher panels and screens between users and at the ends of workstations, along with overhead storage, further divide space.



materials: aesthetics and performance

proper material selection is essential. while materials can add beauty and comfort to the environment, porous materials and non-cleanable textiles may be replaced with smooth, impermeable surfaces and bleach cleanable fabrics. The goal remains to create warm, inspiring workplaces, but performance and cleanability must now take some precedence over pure aesthetics.



well being: physical and psychological

the emotional status of employees is very important as people return from weeks of isolation in the home. while cleanability and space division are imperative, we do not want to create a sterile look and feel, but rather use color, texture and finishes to create comfort and warmth. as always, natural light and fresh air are essential to wellbeing and must be maintained or improved as workstation heights are raised.



comfort: care

how can people feel comfortable, calm, and empowered given somewhat traumatic circumstances? how can staff be assured that proper cleaning protocols are followed? have materials been supplied that allow staff to clean actively throughout the day? are tools and procedures implemented to control proximity to others, the density of people in the office, and the number of visitors admitted?



teknon the way back\

new workspace planning

workspace planning

- 01 providing a variety of spaces for videoconferencing promotes virtual meetings and a reduced number of occupants in traditional meeting rooms
- 02 reduce guest seating in private offices and orient to provide distance
- 03 increasing the height of panels and screens around workstations provides the user protection and a sense of comfort. a variety of workspace types allows the user to choose their desired level of privacy
- 04 plan workstations back to back to increase the distance between users

- 05 reduce the occupancy of café areas, mix single user tables, rectangular tables for two, and community tables with seats spaced at safe distances
- 06 surround open areas with screens to provide protection and add color and texture to a space
- 07 sanitation stations can be placed throughout a space for easy access to cleaning supplies
- 08 lounge areas should include single seats or sofas and benches with tables between to ensure proper distancing

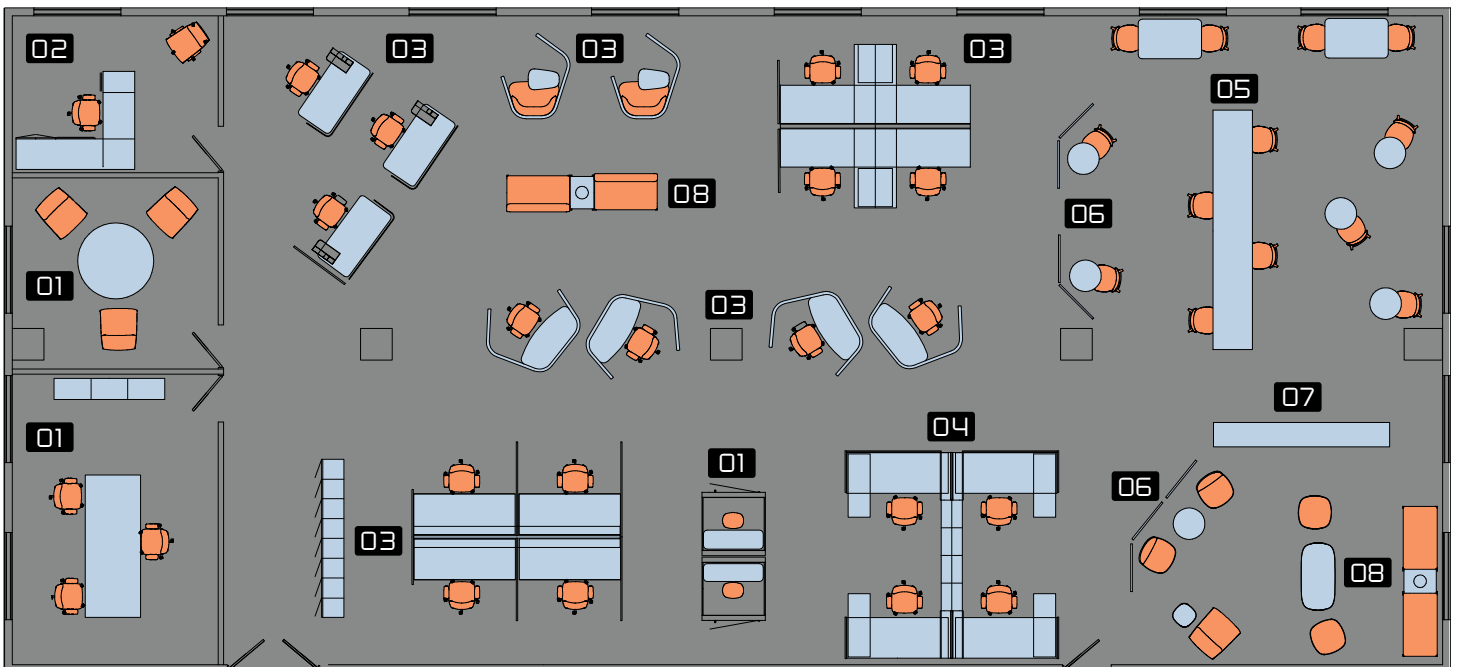

planning with benches

to better define personal space and provide 51" seated privacy, open benches may be fitted with protective screens. free-address benches will transition to assigned seating with enclosure.

end screens

- provide privacy on a corridor
- consider fabric to improve acoustics or solid with a glass top for light transmission

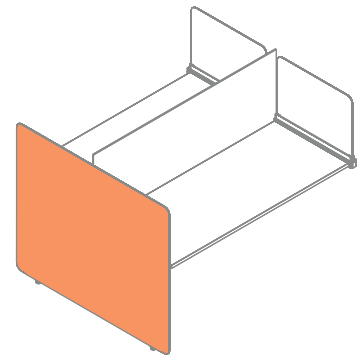

spine screens

- provide face to face privacy
- consider frosted glass for light transmission, or solid screens that add functionality

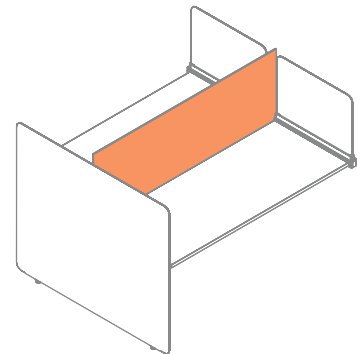

lateral screens

- provide side to side privacy
- consider patterned fabric to add color, writable glass or whiteboard for added functionality

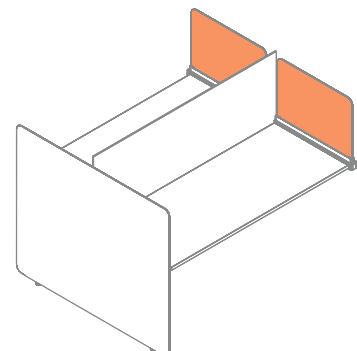

planning with benches

physical distancing guidelines call for 2m between users when retrofitting a bench.

as employees return to work, consider alternating on-site workdays, decreasing the density of users along the bench, or staggering seated employees. beyond reduced density, the addition of screens and storage between users will increase a sense of physical and emotional security.

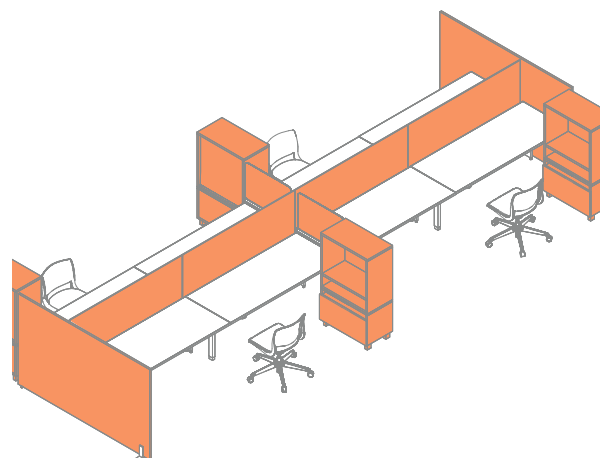
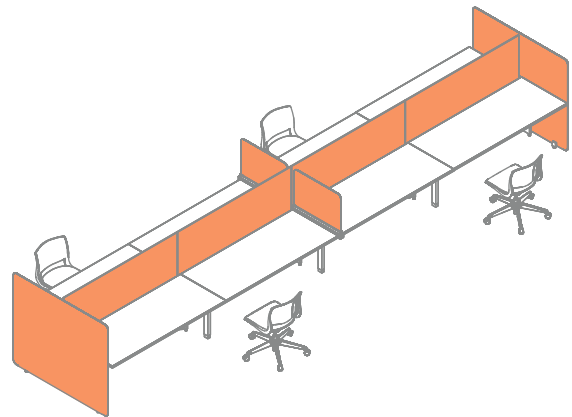
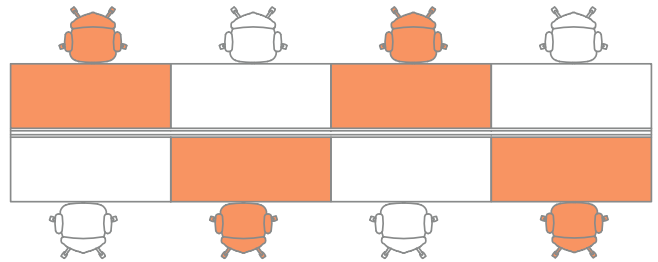

fixed bench

free address

- end screens and lateral screens with bleach cleanable fabric provide privacy and lend a residential feel to the workstation.
- provide storage at each workstation for personal cleaning products.
- address hygiene and spatial constraints with armless chairs upholstered in a polyurethane fabric.



fixed bench

assigned workstations

- . add 51”h solid/glass end and spine screens to provide seated height privacy and protection.
- . a 51”h lateral screen in a bleach cleanable fabric lends a residential feel to a workstation.
- . minimize surface contact with hinged door storage (no handles) that provides a place for personal cleaning supplies
- . a stacker with a frosted glass back adds worksurface area, divides space, and permits light transmission.
- . replace multi-use seating with task chairs in a bleach cleanable fabric to enhance comfort.



height-adjustable bench

free address or assigned workstation applications

- . create 51" h bleach cleanable study carrels for privacy and protection at seated or standing height.
- . provide storage at each workstation for personal cleaning products
- . use armless chairs upholstered in a polyurethane fabric to address hygiene considerations.

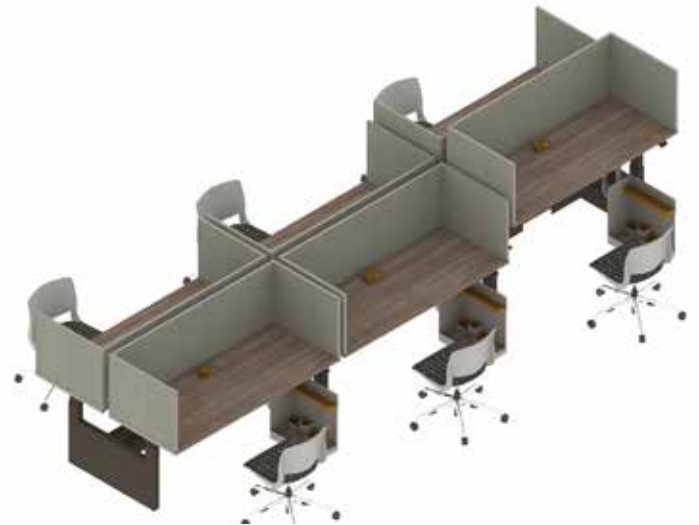

fence with height-adjustable bench

free address or assigned workstation applications

- re-orient tables to eliminate face-to-face positioning.
- divide space with solid or glass screens that provide 51" privacy.
- replace metal lockers with 51" h laminate lockers to discourage perching within workstations.
- desk and side screens in a bleach cleanable fabric add color and warmth, while protecting users as tables are raised or lowered.

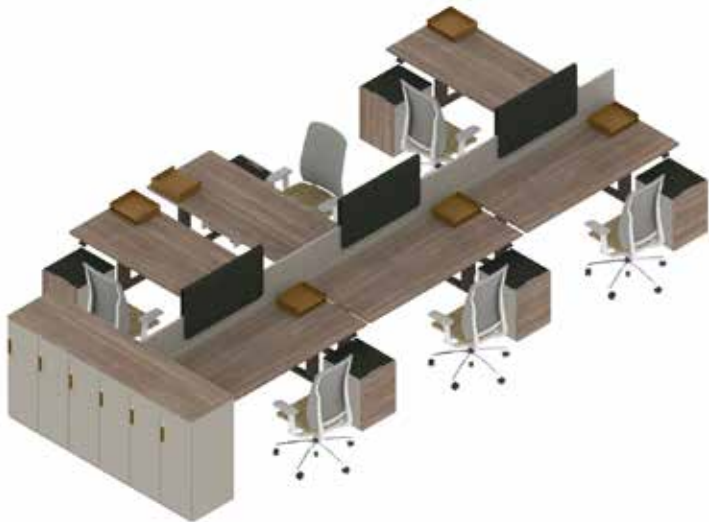

120 degree planning

free address or assigned workstation applications

- 51" h beam-mounted glass screens provide seated privacy and permit light transmission.
- add end screens to the bench in a bleach cleanable fabric.
- top existing credenzas with closed stackers to add personal storage and enhance privacy between users.
- remove collaborative seating from credenzas and bench ends (also allows for 2 additional workstations).
- markerboards provide corridor protection. use a bleach cleanable fabric on one side to add functionality and warmth.



workstation planning

as privacy and physical distancing assume greater importance, panels may increase to 51" or 66" in height and collaborative furniture within workstations may be removed.

- screens on the fronts and sides of worksurfaces provide three sides of protection. lateral screens will divide space between back-to-back users
- re-orient workstations so that employees do not work face to face.

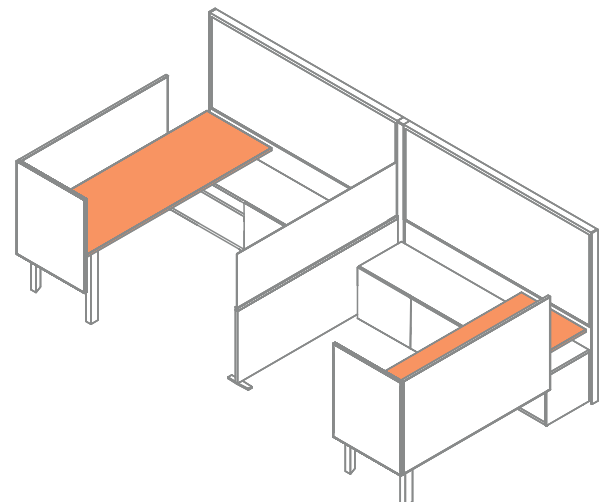
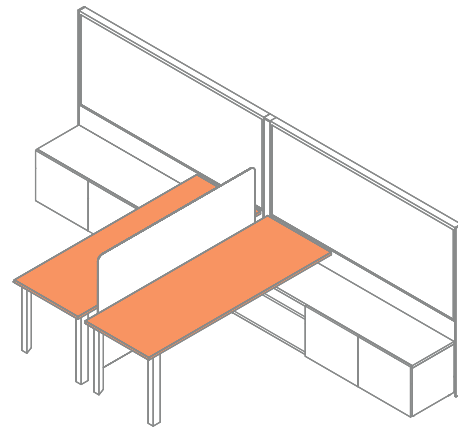
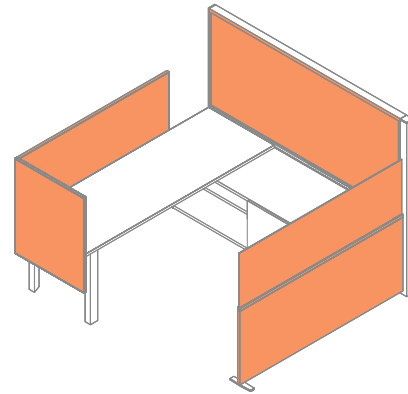

low panel workstations

fixed height face-to-face applications

- rotate worksurfaces and credenzas so that users are no longer face to face.
- replace 13" glass add-on panels, end trims, and connectors to increase spine panels to 66" in height.
- add bleach cleanable 51"h framed fabric screens to the front and side of each workstation.
- install laminate and glass lateral screens to create an additional barrier between users.
- remove collaborative cushions.
- where possible, replace storage with laminate cabinets with no handles to minimize surface contact and provide a place for personal cleaning products.



semi-enclosed workstations

fixed height side-by-side applications

- remove accessory rails or other metal components that can collect dirt or microbes and replace with solid or bleach cleanable fabric fascias.
- replace porous fascias with solid cleanable surfaces.
- add floor screens at the ends of worksurfaces to shield users from corridor traffic.
- maintain open shelves but remove fabric tackboards or replace with writable or back-painted glass.
- replace metal pulls with brass pulls
- remove cushions from pedestals

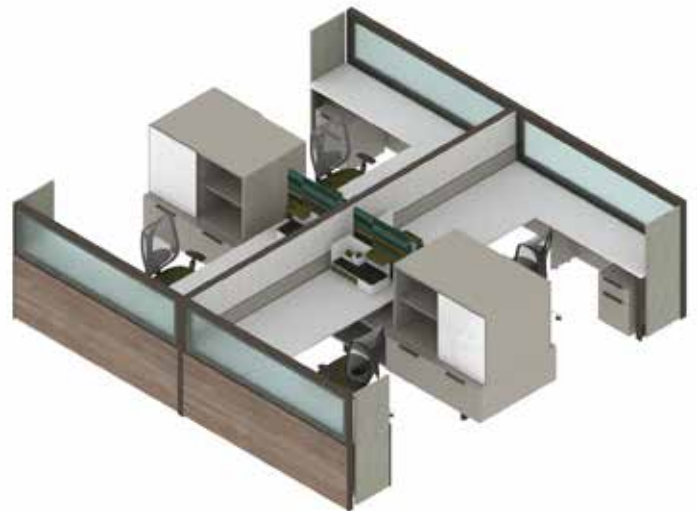
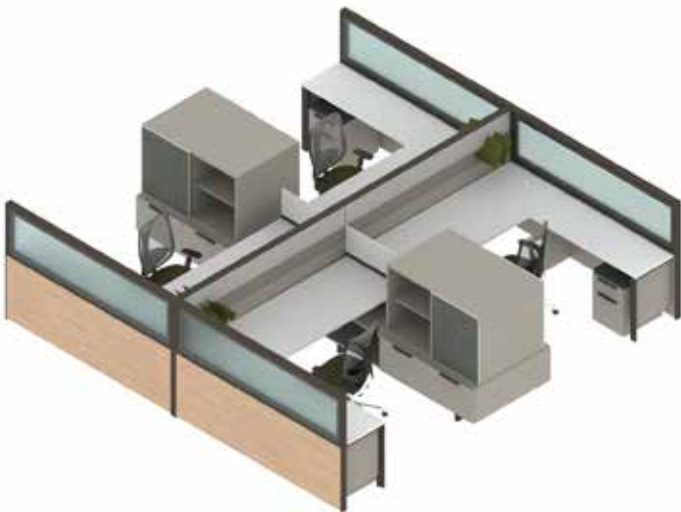

high collaborative workstations

fixed height back to back applications

- replace exterior elements with a bleach cleanable fabric element.
- replace metal storage (overheads) with laminate and glass front cabinets.
- remove collaborative furniture.
- add easels with bleach cleanable fabric between users to provide protection.
- add fabric screens at the ends of worksurfaces to provide corridor privacy.

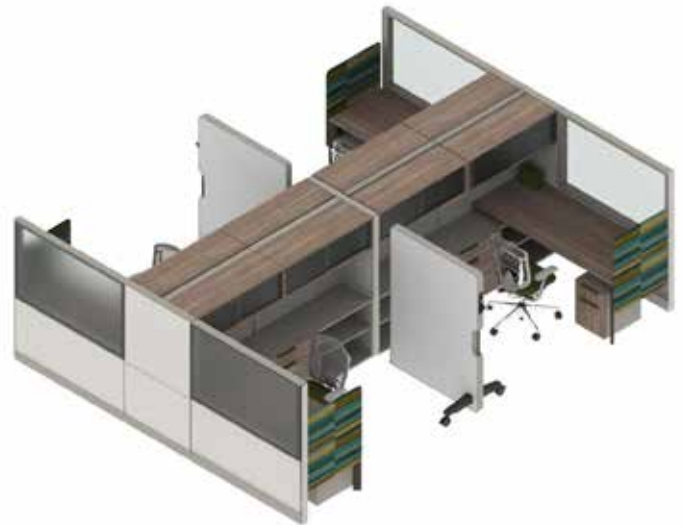

private office

- reorient desks to create further distance from guest seating and place monitors between the user and guest
- replace lounge chairs with a more upright chair in a bleach cleanable fabric to discourage long meetings.

- remove collaborative cushions.
- replace wall-mounted fabric tackboards with whiteboards or writable glass.



teknion the way back\

new
social
space
planning

social spaces

- add lite wall screens in a bleach cleanable fabric to add privacy
- replace top with laminate or glass
- specify lounge seating in a coated or bleach cleanable fabric

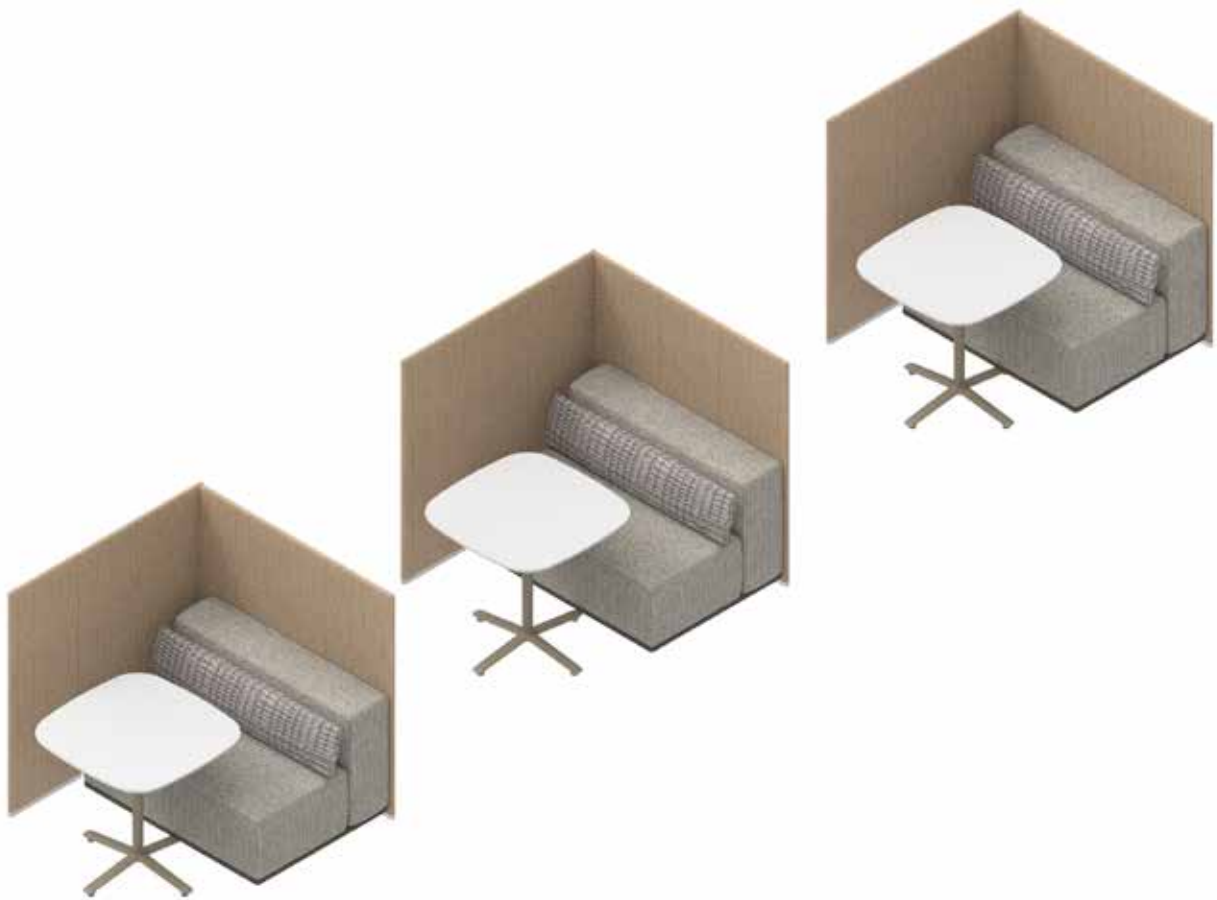

social spaces

- replace upholstered seats in clique with table top surfaces (cr required)
- add a larger table top to collaborative to increase distance between collaborators
- add bleach cleanable fabrics to upholstered items
- replace top with laminate or glass surface



social spaces

- rearrange pieces to cocoon each person in high back lounge chairs
- replace top with laminate or glass surface
- add bleach cleanable fabrics to upholstered items



social spaces

- rearrange pieces to cocoon each person in high back lounge chairs
- replace top with laminate or glass surface
- add bleach cleanable fabrics to upholstered items



social spaces

- rearrange lounge and tables to allow for more distance between seated users
- replace top with laminate or glass surface
- add bleach cleanable fabrics to upholstered item

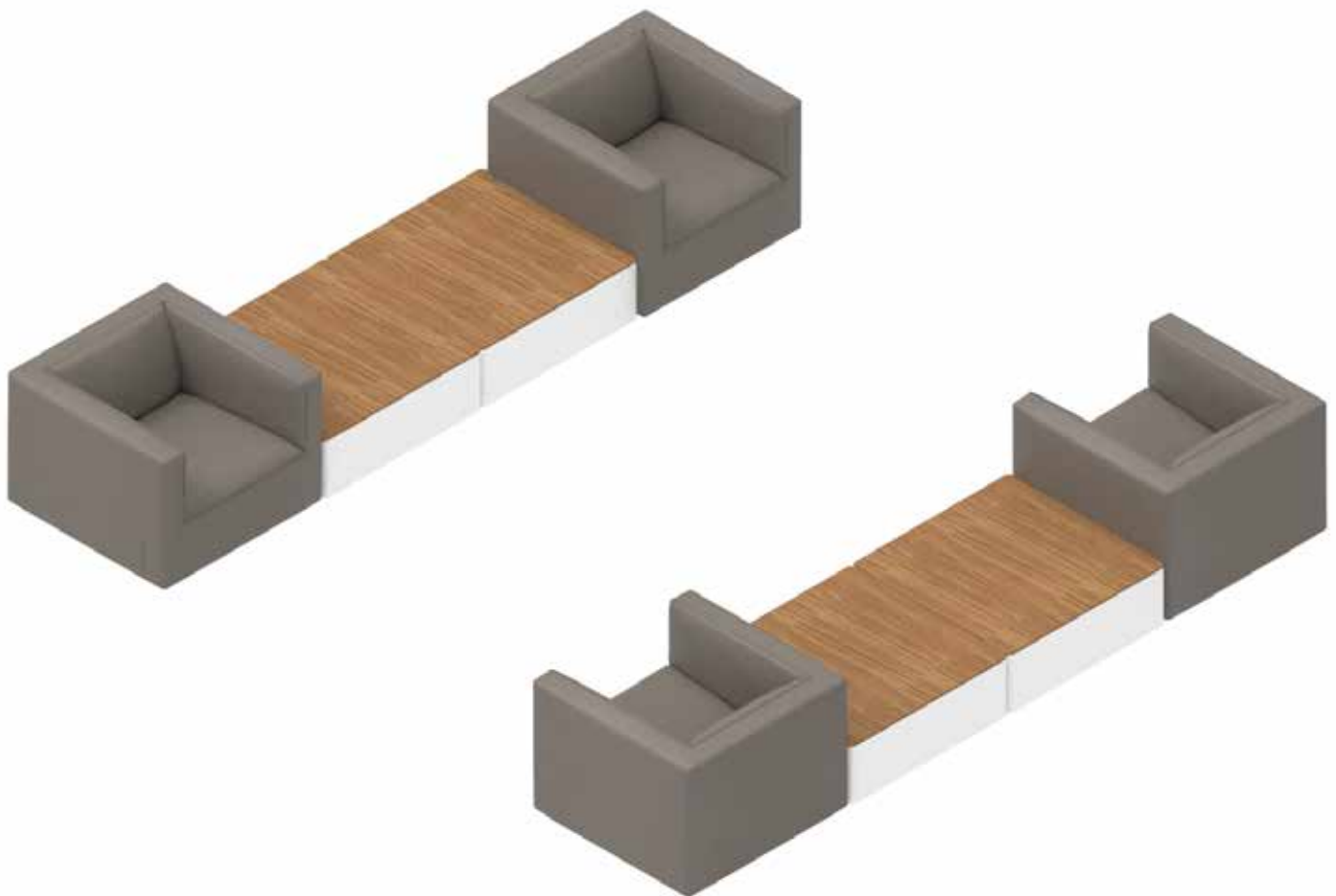

teknion the way back\

materials

loom textiles

loom creates design-driven, performance-oriented woven and coated fabrics for modern interiors. as concerns about hygiene and safety arise, loom provides detailed product information to help educate clients on safe and effective ways to clean and care for textiles. loom does not promote the use of antimicrobial finishes as these products do not kill the novel coronavirus that causes covid-19. such topical agents only inhibit the growth of bacteria and other microbes, and antimicrobial finishes can be harmful to human health and the environment alike. we encourage prevention and perspective while maintaining a healthy workplace. cleaners such as soap and water in conjunction with household disinfectants like bleach can be effective against the spread of viruses. maintain perspective and clean “high touch” surfaces first.

further information regarding cleaners and disinfectants can be found on the centers for disease control and health canada websites. loom’s website offers specific filters to help find your textile solution faster and easier. filter by application or performance, to name a few – and select the right textile for your unique project. visit loomtextiles.com

soap and water cleanable fabrics

cleaning products remove germs, dirt and impurities from surfaces using soap (or detergent) and water. cleaning does not necessarily kill germs, but by removing them, it lowers their numbers and therefore the risk of spreading infection". luum offers over 90 products with cleaning code "w" and/or "ws". these fabrics if needed, can be cleaned with soap and water.

multipurpose (upholstery/ wrapped wall/panel)

actuate, bitstream, complement, digi tweed, ghat, heather tech, intone, marl cloth, percept.

upholstery

amalgam, ample, arc angle, beaded stripe, color fuse, crossdye, disrupt, doyenne, duo chrome, ephemera, fine grain, filar, flexagon, flex wool, fundamentals, heather felt, implex, iterate, line language, magnify, meta texture, miami, modulus, monotex, navigate, outpress, perilune, point to point, point set, refraction, schema, situ, stimuli, structured stripe, substance, superspun, synaptic, thangka, top coat, two tone, ultra durable, vector, velvet underground, vital.



wrapped wall and/or panel

arc angle, artopia, bandeau, beeline, carreaux, crossdye, duo chrome, egypt, emit, essentials, fleck forge, heather felt, india, jetline, linen weave, lustrado, makah, meme, navigate, nitty gritty, outpress, peru, presse, rationale, tangle, topology, vista, twining, wales, warp speed, wired up.

direct glue

datatown, dhurga, fleck forge, mica shift, soft ridge, strio, telecity, twining.
drapery: backdrop, dispersion

bleach cleanable fabrics

as per the cdc, “disinfectants kill germs on surfaces. by killing germs on a surface after cleaning, you can further lower the risk of spreading infection. epa-approved disinfectants are an important part of reducing the risk of exposure to covid-19”.

over 30 luum fabrics are bleach cleanable. please see the care instructions for each textile for the recommended bleach to water ratio and always rinse. additional bleach cleanable information can be found at luumtextiles.com.

[click here](#) to view per-filtered bleach cleanable textiles options.

coated upholstery

fine grain, meta texture, monotex, perilune, synaptic, top coat and ultra durable

woven upholstery

bitstream, disrupt, doyenne, duo chrome, ephemera, flexagon, intone, iterate, line language, modulus, outpress, point set, point to point, schema, structured stripe, substance, thangka, two tone, vector and vital.



wrapped wall

bitstream, duo chrome, emit, intone, outpress and structured stripe

direct glue wallcovering

dhurga, fleck forge, mica shift and soft ridge (certain colorways).

fabrics and anti-microbial finishes

an anti-microbial finish is a chemical treatment applied to a fabric to inhibit the growth of micro-organisms, including bacteria, mold, and mildew. an anti-microbial finish will not kill a virus. [click here to view pre-filtered antimicrobial textile options.](#)

luum promotes the use of silicone fabrics as a healthy workplace option. luum's silicone product, top coat, is inherently antimicrobial as silicone, by nature, does not support microbiological growth. silicone is also easily cleanable with soap and water or the correct bleach to water ratio. top coat has also been tested for the use of healthcare grade wipes and sprays. [click here to view top coat's colorline.](#) please see the "care for silicone upholstery" on the luum website for a list of tested disinfectants and viricides.

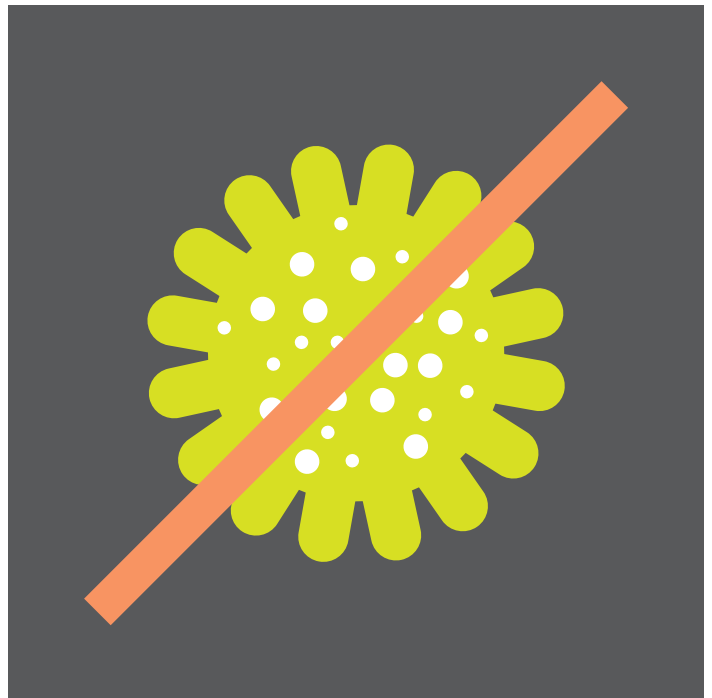

viricide-cleanable

luum has several fabrics that can be disinfected with healthcare grade cleaners like viricide wipes and sprays: meta texture, monotex, perilune, synaptic, top coat and ultra durable are coated fabrics. disrupt, iterate, schema and vital are woven fabrics. for more information, please see the care and maintenance section of the luum website, luumtextiles.com.

oxivir wipes

schema and iterate

virex wipes

disrupt and vital

virex + more

top coat

virex, oxivir + more

meta texture, monotex, perilune, synaptic and ultra durable

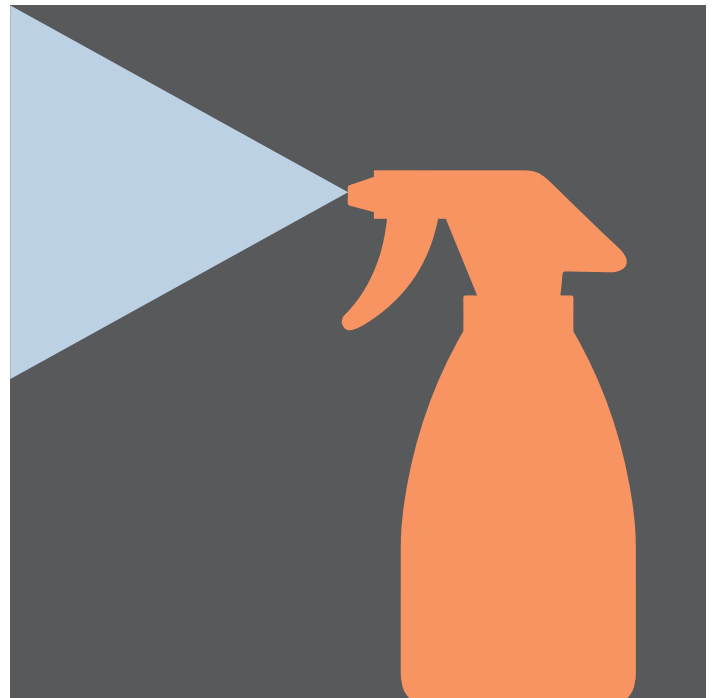

teknion the way back\

bleach

cleanable

color

palettes

bleach cleanable warm yellow palette



- 01 structured stripe double beam
- 02 top coat polish
- 03 flintwood pecan
- 04 intone crème
- 05 atrium white
- 06 duo chrome canvas

bleach cleanable blue palette



- 01 structured stripe
box motion
- 02 top coat shell
- 03 flintwood
white oak
- 04 intone
white noise
- 05 duo chrome
aquamarine
- 06 accent paint
azure

bleach cleanable green palette



- 01 structured stripe block draw
- 02 mineral teal
- 03 dusk vapor
- 04 flintwood flax
- 05 duo chrome citron
- 06 top coat shellac
- 07 outpress sand

bleach cleanable red palette



- 01
intone pome
- 02
atrium white
- 03
flintwood blonde
maple
- 04
vector horizon
line
- 05
duo chrome
persimmon
- 06
top coat conduct

bleach cleanable ochre palette



- 01
duo chrome
boysenberry
- 02
atrium white
- 03
flintwood flax
- 04
duo chrome
hydrangea
- 05
top coat toast
- 06
terracotta

bleach cleanable neutrals palette



- 01
schema
vanishing point
- 02
butternut
- 03
flintwood flax
- 04
ultra durable iced
coffee
- 05
emit dazzle
- 06
crisp grey

teknion the way back

often when
you're at the
end of something,
you're at the
beginning of
something else.

fred rogers

with the advent of 2020, few of us imagined the personal, professional, and economic hardships that lay ahead for so many. still, i believe that life altering events like the emergence of the coronavirus can ultimately lead to positive change.

i remain hopeful that as we return to “normal,” we will begin to see the world and our place in it a little bit differently, that we will act with more courage and ingenuity as leaders, communities, and institutions.

it may be too early to tell, but i have a sense of possibility about the future and the potential of revising the ways we as a society conduct business, the ways in which we design, build, and work. i also feel confident in asserting that good design may matter now more than ever.

it is rewarding to see the spirit with which so many in our industry have responded to this global crisis. i hope you find this guide to be instructive and useful as we find our way back in to work.

david feldberg,
president and chief executive officer of teknion

teknion the way back

www.teknion.com

in canada
1150 flint road
toronto, ontario
m3j 2j5 canada
tel 866.teknion
866.835.6466

in the usa
350 fellowship road
mt laurel, new jersey
08054 usa
tel 877.teknion
877.835.6466

other offices located in
europe, south and central america,
middle east, asia and russia
for regional contact information
go to www.teknion.com

@teknion 2020

brochure design: vanderbyl design